

LVAF/WAKA Kickball Rules

How to Play Kickball - Basic Rules

The most important rule - Have fun, kickball is about having fun and being social.

Below is the basic setup and rules for a kickball game, each section below has additional details and subtleties. For more detailed and complete full set see our full rulebook further down the page.

Kickball is a simple game consisting of two teams, bases, and a big red ball. Played like baseball, the goal is to score more runs than the opposing team. Here is a list of general rules/concepts central to gameplay, from team structure to other less discussed rules.

- 10 fielders.
- 6 innings (if time allows).
- 2 base coaches.
- Ball must be rolled across home plate
- Strike zone is 1 ft on all sides of the home-plate (and above)
- You can throw a runner out, but no headshots. Players under the age of 18 must be tagged out or thrown out at the base.
- one base on an overthrow.
- forced outs.
- no ghost men.
- No Sliding

Once teams are assembled, one team takes the field and the other prepares to kick. Play begins when the pitcher rolls the ball to the kicker. Once the kicker kicks the ball, they run around the bases in order depending on how far they kick the ball - further kicks will afford the runner more time to traverse more bases.

If the ball lands in the foul zone, the kicker must try again, and the foul will count as a strike. If a fielding player catches the ball before it touches the ground, the kicker is automatically out. If a fielding player manages to get the ball and pass it to one of the players on the base the runner is going to before the runner gets there, the runner is out. If any fielding player manages to touch the runner with the ball while holding it in their hand, the runner is out.

When a player makes it around all bases and returns to the home base, the kicking team scores a run. The kicking team should aim to score as many runs as possible in an inning without getting out. If three of the kicking team's players get out, the teams switch positions. Once both teams have had a turn in the field and at the plate, the inning ends. Whichever team has the most points at the end of 6 innings (or fewer if you want to play a shorter game) wins the game.

Full Rulebook

Kickball At A Glance

WAKA Kickball - The World Adult Kickball Association is the preeminent adult kickball organization and the world governing body of kickball. Kickball is a simple game consisting of two teams, bases, and a big red ball. Played like baseball, the object is to score more runs than the opposing team. In short, games are

LVAF/WAKA Kickball Rules

played with 10 fielders, 6 innings (if time allows), 2 base coaches, no head shots, one base on an overthrow, forced outs, no sliding and no ghost men. The following rules will govern all kickball games. For the enjoyment of all, proper respect and civility is required of all participants toward one another. Fighting is not allowed or tolerated.

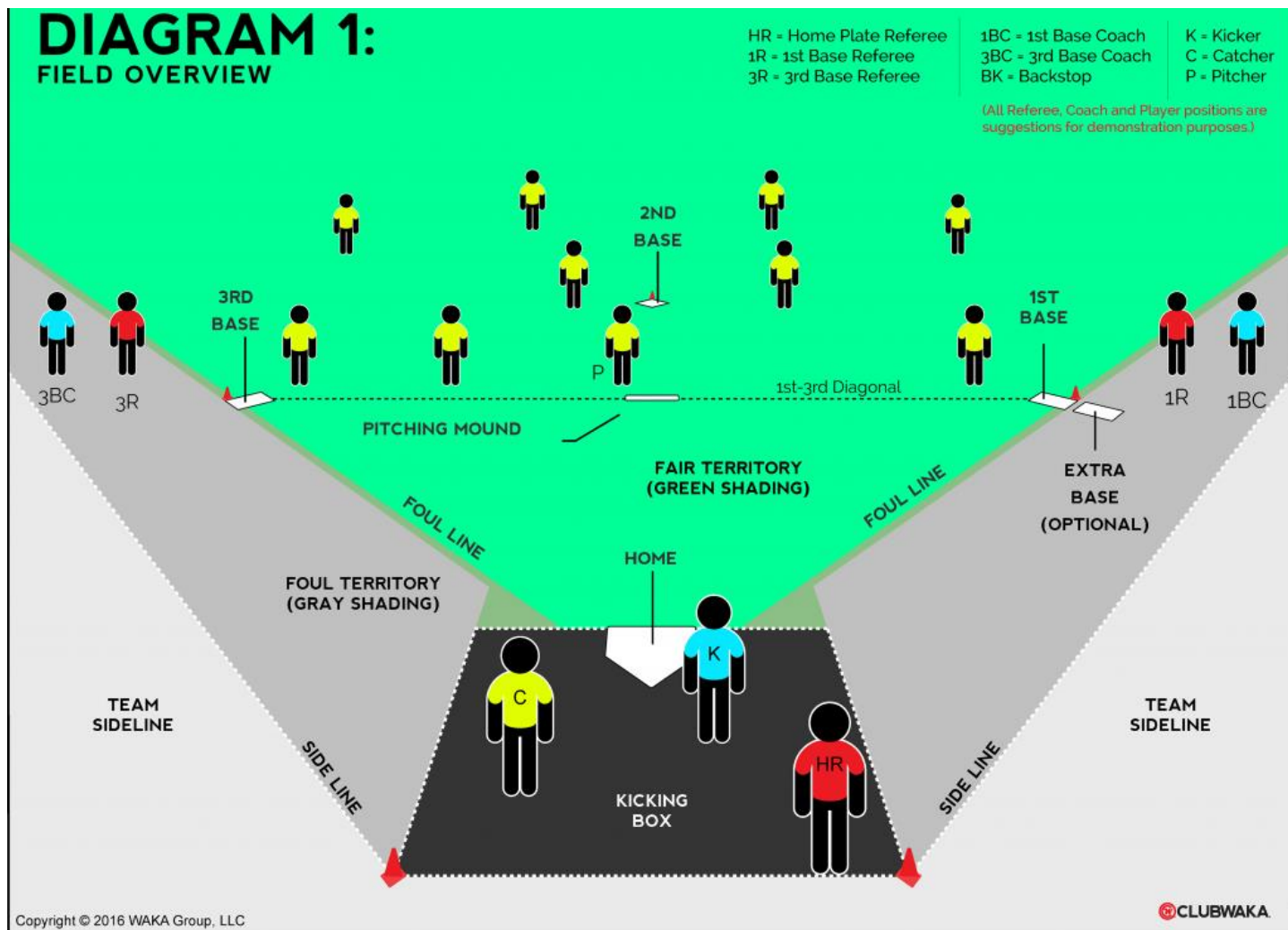

1. The Playing Field

1.01 The field shall be established on any safe terrain suitable for play in accordance with the following provisions which equal the dimensions of a softball field (see Diagram 2):

1. the kickball diamond is a square with equal sides of 60 feet or about 20 paces with a base at each corner;
2. the distance from home plate to second base and from first base to third base is 84 feet 10 1/4 inches or about 28 paces. The distance between any base and home plate shall be measured from the back corner of each;
3. the pitching strip is in the center of the diamond, 42 feet 5 1/8 inches or about 14 paces from home plate, and directly aligned with the 1st-3rd base diagonal;
4. the pitching mound extends 12 feet from the center of the pitching strip (see Rule 8.02);
5. the sidelines are lines 10 feet on the outside of and parallel to the foul lines, the area between the foul lines and the sidelines is the sideline area (see Rule 1.07);

LVAF/WAKA Kickball Rules

6. when available, cones are placed: at the outside corner of first, second, and third base, and not touching the base; on the foul lines 30 feet or about 10 paces behind first and third base; and on the sidelines 10' from home plate;
7. the kicking box is a rectangle with the front of the box aligned with the front of home plate and the back of the box aligned with the sideline cones behind home plate. Lines extending forward from the sideline cones perpendicular to the front of home plate make up the sides of the kicking box. The kicker is not required to start in the kicking box, however the kick must occur within the kicking box (see Rule 9.02b).
8. the foul lines are fair territory.

1.02 The strike zone is a three-dimensional irregular pentagon based on the shape of home plate and is one (1) foot in height. The front of the zone aligns with the front of home plate. The sides of the zone extend one (1) foot to either side of the plate. The back edges of the zone are one (1) foot from the back sides of the plate (see Diagram 4). The strike zone may not be marked by cones or other raised objects.

DIAGRAM 4: STRIKE ZONE

The Strike Zone extends 1' out from the side and rear edges of Home Plate (4a) and up to 1' directly above that plane (4b). (The Strike Zone is subject to Home Plate Referee's perception.)

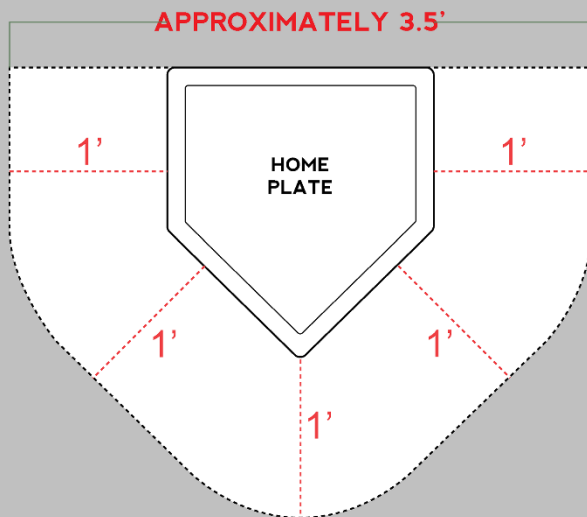

4A: TOP VIEW OF STRIKE ZONE
(white shading)

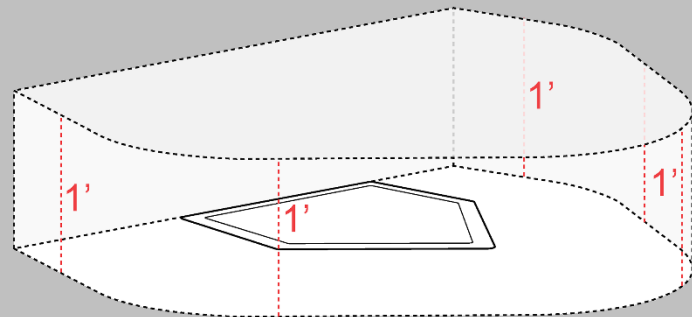

4B: 3D VIEW OF STRIKE ZONE
(white shading)

Copyright © 2016 WAKA Group, LLC

CLUBWAKA

1.03 All participants must respect and obey all rules and regulations pertaining to the field used for games.

1.04 Any player or Referee wholly or partly in fair territory is an extension of fair territory. Any live base runner outside the kicking box is fair, even when wholly in foul territory. A player jumping from fair territory is in fair territory while in the air. A player in foul territory does not extend foul territory by jumping or reaching into fair territory.

1.05 Upon notification to the Head Referee of any improper field set up, the field layout shall be corrected before the beginning of the next play. Protest based on field set up will not be considered.

1.06 - Optional Extra Base: When available, an additional base may be set up adjacent to First Base to provide more room for the runner (see Diagram 5).

LVAF/WAKA Kickball Rules

DIAGRAM 5: OPTIONAL EXTRA BASE

(See Rule 1.06)

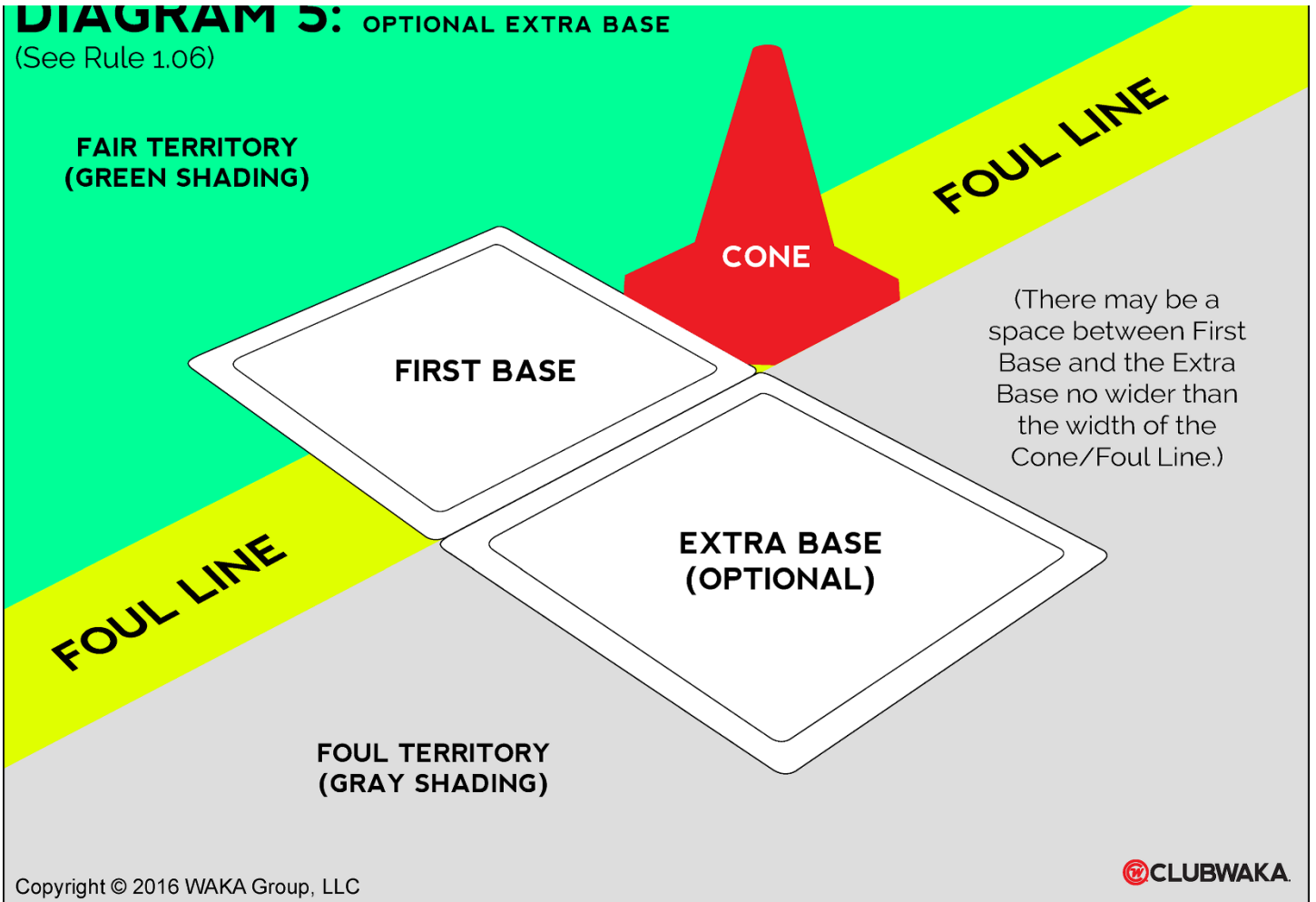

If an extra base is used:

1. The Extra Base is only available for runners traveling from home plate (see Rule 10.06);
2. Fielders trying to make an out on first base must touch the base in fair territory (the First Base). Runners hindered by a fielder touching the base in foul territory (the Extra Base), will be safe;
3. When a play is attempted at first base, a runner who touches the First Base prior to being called safe at the Extra Base shall be called out, except under the exception in Rules 1.06f and 1.06g;
4. Once a runner has reached first base safely the runner must start the next play on the First Base. Any runner standing on or touching the Extra Base at the beginning of the next play will be out;
5. No additional base may be used at any other base;
6. The Runner is permitted to use the First Base if avoiding collision with a fielder in foul territory. In this event, the fielder in foul territory is permitted to tag the Extra Base (see Rule 14.02o);
7. The runner may use First Base if attempting to advance to Second Base, or if there is no fielder on First Base. A runner (see Rule 1.06a) using or touching First Base in any other circumstance is out.

1.07 Sideline area. Prior to the kick, no participants (or spectators) may be in the sideline area (see Rule 1.01e and Diagram 2) except for the kicker, Referees and designated base coaches (see Rule 6.01). After the kick, fielders and base runners in the process of playing the game may also occupy the sideline area. The first infraction of this rule will result in a warning to the team that caused the infraction. The second and each subsequent infraction will result in an out for the next kicker in the written kicking order on the team that caused the infraction.

LVAF/WAKA Kickball Rules

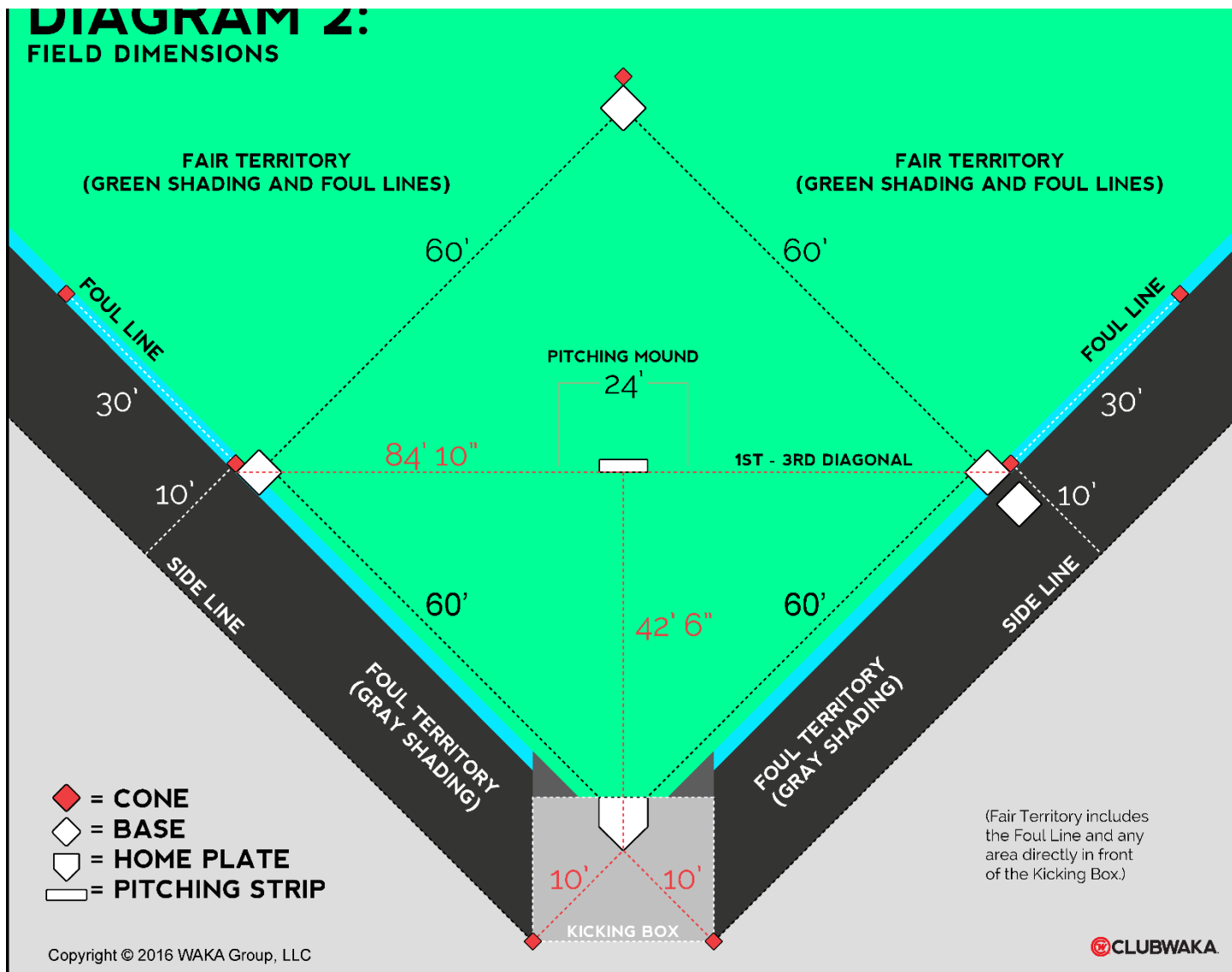

2. Equipment

- 2.01 While participating, players must properly wear the official athletic clothing designated for their use.
- 2.02 Athletic shoes are required. Metal cleats are not allowed.
- 2.03 Players may wear protective equipment providing it does not offer the wearer an unfair performance advantage. Any equipment deemed by the Head Referee (see Rule 3.01) as a performance enhancement must be removed or the player will be removed from play.
- 2.04 The official kickball is the red WAKA Logo Kickball, measuring 10 inches in diameter when properly inflated to a pressure of 1.5 pounds per square inch.
- 2.05 All player attire is an extension of the player.

3. Referees

- 3.01 Games must be officiated by at least one authorized official, the Head Referee. When available, at least two officials referee each game: a Head Referee, and a First Base Referee. The Head Referee governs all gameplay and issues all final rulings, and has final authority on equipment issues. Other Referees may assist these officials when available.
- 3.02 Prior to each game, the Head Referee must conduct a meeting with the Captains of each team, to address any ground rules in effect, to ensure the exchange of team lineups (see Rule 4.01), and to identify

LVAF/WAKA Kickball Rules

the designated Captains who will be authorized to discuss calls with the Referees during the game (see Rule 5.03).

3.03 Referees have jurisdiction over play and may:

1. call a timeout;
2. call off a game due to darkness, rain or other cause at the Referee's discretion;
3. penalize a player, including game ejection, for any reason. This includes but is not limited to unsportsmanlike conduct, fighting, delay of game and excessive verbal abuse. Ejected participants must leave the field area and may not return to the game.

3.04 Referees have jurisdiction over play and must:

1. cancel the game if lightning is seen, or delay it until safe to continue;
2. keep a record of the final game score.

3.05 Referees may make rulings on any points not specifically covered in the rules (at the time of occurrence), but the ruling shall not be deemed as a precedent for future rulings.

4. Player Eligibility

4.01 All participating players must appear on written lineups, reflecting that game's kicking order, to be exchanged between the captains of each team before play begins.

4.02 A claim of improper kicking order must be made to the Head Referee who will make the final determination. Such a claim must contain two parts:

1. that the written kicking order was exchanged in accordance with Rule 4.01;
2. that the claim is made on the field no sooner than the first pitch thrown to the accused "wrong" kicker, and no later than the first pitch thrown to the subsequent kicker.

The burden of proof rests with the accused team. Any resulting play is nullified by a finding of improper kicking order, with an out recorded for the "wrong" kicker (see Rule 14.02i). A player removed from the kicking order for ejection, injury, illness, or any reason (per Rule 16.02) does not constitute an improper kicking order.

5. Teams

5.01 Each game shall have two (2) participating teams: the Away team, which kicks first each inning, and the Home team, which kicks last each inning.

5.02 While fielding, each team must field at least eight (6) and no more than ten (10) players. This must include one pitcher and one catcher at all times during the game.

5.03 For a given game, each team shall have one Captain and one Co-Captain (collectively "the Captains") who are jointly responsible for the team. The Captains may discuss calls with the Head Referee, but must accept the Head Referee's final ruling. Other players besides the Captains that dispute calls with the Referees are subject to ejection from the game (see Rule 3.03c).

6. Base Coaches

6.01 Two members of the team at kick may coach first and third base, switching as needed with other team members to remain in the proper written kicking order.

6.02 Base coaches may not physically assist runners while the ball is in play (see Rule 14.02h).

LVAF/WAKA Kickball Rules

7. Regulation Games

7.01 Regulation games last seven (6) innings or no more than 55 minutes.

1. In the event of a tie score at the end of the game, the game shall go into sudden death and first team to score wins.
2. If the Home team (see Rule 5.01) already leads the game when the bottom of the final inning is reached, that team wins the game instantly and the game is over.
3. If the Home team (see Rule 5.01) takes the lead during the bottom of the final inning, that team wins instantly and the game is over.
4. No new inning may begin 50-minutes past the scheduled start time of a game. Any inning that has begun before the 50-minute mark may be completed in its entirety as long as it does not exceed 55 minutes. Any game still in progress at the 55-minute mark shall be called due to time and the final score will revert back to the previous completed inning (see Rule 7.02).

7.02 A game that is called off by the Referee (see Rules 3.03, 3.04) after three (3) full innings of play shall be considered a regulation game. The game score at the end of the last full inning shall determine the winner. Regulation games called off that end in a tie shall be marked as a tie.

7.03 A game that is called off by the Referee for any reason before three (3) full innings of play shall not be considered a regulation game and a new game may be rescheduled.

8. Pitching, Catching, and Fielding

8.01 Balls must be pitched by hand. There are no restrictions on pitching style. Except no bounce pitches

8.02 Proper Field Position must be maintained by all fielders while a pitch is in progress, and until the pitched ball reaches the kicker. Failure to be properly positioned will result in a Position Warning to the team that caused the infraction. The team's second and each subsequent Position infraction by that team that game will result in the kicker being awarded first base regardless of the outcome of the kick. Proper field position is:

1. For Fielders: All fielders besides the catcher must remain in fair territory behind the 1st-3rd base diagonal;
2. For Pitchers:
 1. The pitcher must start the act of pitching with at least one foot within the pitching mound (see Rule 1.01d);
 2. The pitcher must have at least one foot on or directly behind the pitching strip (see Rule 1.01c) when releasing the ball;
 3. No part of the pitcher's front foot may be in front of or across the front edge of the pitching strip.
3. For Catchers:
 1. The catcher must be positioned within or directly behind the kicking box and behind the horizontal plane of the kicker, parallel to the front edge of home plate.
 2. The catcher may not make contact with the kicker, nor position so closely to the kicker as to restrict the kicking motion.
 3. The kicker may not trigger a position violation through maneuvers judged by the Ref to be deliberately tricky or unsportsmanlike.

9. Kicking

LVAF/WAKA Kickball Rules

9.01 All kicks must be made by foot or leg, below hip level (see Rule 13.02e). Any ball touched by the foot or leg below hip level is a kick.

9.02 All kicks must occur:

1. at or behind home plate. The kicker may step on home plate to kick, however no part of the planted foot may be in front of or cross the front edge of the home plate (see Rule 13.02g).
2. within the kicking box (see Rule 1.01g). The kicker must have at least a portion of the plant foot within the kicking box during the kick (see Rule 13.02g). The kicker may line up outside of the kicking box.

10. Running and Scoring

10.01 Runners must stay within the baseline. Any runner outside the baseline is out (see Rule 14.02k):

1. Runners may choose their path from one base to the next, and may follow a natural running arc;
2. Runners are free to change course to avoid interference with a fielder making a play;
3. When attempting to avoid a ball tag, runners may move no more than 4 feet out of their established path.

10.02 Obstruction. Fielders may be within the baseline when doing so is necessary to make an active play on the ball, but must otherwise stay out of the baseline. Runners hindered by any fielder within the baseline, not making an active play for the ball, shall be safe at the base to which they were running. Runners may choose to advance beyond this base while the ball is still in play.

10.03 Neither leading off base, nor stealing a base is allowed. A runner may advance once the ball is kicked. A runner off base when the ball is kicked is out (see Rule 14.02g).

10.04 Hitting a runner's neck or head with the ball is not allowed. Any runner hit in the neck or head shall be considered safe at the base they were running toward when the ball hits the runner. If the runner intentionally uses the head or neck to block the ball, and is so called by the Referee, the runner is out.

10.05 A tag-up is a requirement to retouch or stay on a base until a kicked then caught ball is first touched by a fielder. After a tag-up a runner may advance. A runner failing to tag-up as required is out (see Rule 14.02f).

10.06 All ties will go to the runner. Runners traveling from home plate may overrun first base and may only be tagged out if actively attempting to advance to second base.

10.07 Base Running on Overthrows.

1. an overthrow is a ball thrown, kicked, or deflected into foul territory while making a defensive play toward a player or base;
2. a runner may advance only one base beyond the base the runner is on or running toward when the ball travels into foul territory.
3. one base on an overthrow is a restriction on the runner – not an automatic right for the runner to advance;
4. if any fielder attempts to make an out prior to returning the ball to the pitcher, runners may commence base running.

LVAF/WAKA Kickball Rules

10.08 Running past another runner is not allowed. The passing runner is out (see Rule 14.02j).

10.09 A run scores when a runner touches home plate before the third out is made, EXCEPT that no run can score when the third out is made during a force play situation, or when the kicker is put out before touching first base. At the end of a game the team with the most runs wins.

10.10 When a base is displaced during play, any runner is safe while in contact with the base's original and correct location. All displaced bases should be restored at the end of each play (see Rule 1.01b).

11. Strikes

11.01 A count of three (3) strikes is an out.

11.02 A strike is:

1. a pitch that is not kicked and is not called a ball per Rule 12.03, that enters any part of the strike zone (see Rule 1.02);
2. an attempted kick missed by the kicker inside or outside of the strike zone (see Rule 1.02).

11.03 Foul balls never count as strikes.

12. Balls

12.01 A count of four (4) balls advances the kicker to first base, with the exception of four-pitch walks (see rule 12.02).

12.02 During a single plate appearance, if a kicker is walked on exactly four pitches, without being pitched any strikes (see Rule 11) or any resulting foul balls (see Rule 13.02), the kicker will be awarded a walk of two bases. Base runners shall only advance as far as they are forced by the kicker proceeding through 1st base to 2nd base.

12.03 A ball is:

1. a pitch outside of the strike zone as judged by the Referee where a kick is not attempted (see Rule 1.02);
2. a pitched ball that does not roll before reaching the kicking box;
3. a pitched ball that exceeds one foot in height from the bottom of the ball at any time while passing through the kicking box, prior to reaching the kicker;
4. a pitched ball that is higher than one foot at the plate.

13. Fairs and Fouls

13.01 A count of three (3) fouls is an out. Foul balls never count as strikes.

13.02 A foul ball is:

1. a kicked ball first touching the ground in foul territory (see Rule 1.01h, Diagram 3D);
2. a kicked ball first touching a fielder or Referee wholly in foul territory, while the ball is over foul territory (see Rule 1.04);
3. a kicked ball landing in fair territory, but touching the ground in foul territory on its own at any time before crossing 1st or 3rd base (see Rule 1.01h, Diagram 3C, 3D);
4. a kicked ball landing in fair territory, then entering foul territory before crossing 1st or 3rd base, and touching a fielder or Referee wholly in foul territory (see Rule 1.01h, Rule 1.04);
5. a ball put into play with any part of the kicker's body at or above the kicker's hip level (see Rule 9.01);
6. a kicked ball touched more than once or stopped in the kicking box by the kicker;

LVAF/WAKA Kickball Rules

7. a kicked ball first kicked outside of the kicking box (see Rule 9.02) (see Diagram 3C);
8. a kicked ball first touching a permanent object, such as a batting cage or fence.
9. a kicked ball first touching a fielder in front of the kicker's box prior to the ball crossing into fair territory
10. a kicked ball by a player that comes to a full stop prior to crossing the 1st-3rd diagonal line without first being touched by a defensive player.

13.03 A fair ball is:

1. a kicked ball landing and remaining in fair territory (see Rule 1.04) (see Diagram 3A);
2. a kicked ball landing in fair territory then traveling into foul territory at or beyond 1st or 3rd base (see Diagram 3A, 3B).
3. a kicked ball first touching a player or Referee in fair territory (see Rule 1.04);
4. a kicked ball landing in fair territory, then touched by a participant in fair territory before touching the ground in foul territory (see Rule 1.04);
5. a kicked ball that touches a runner before touching the ground in foul territory (see Rule 1.04);
6. a kicked ball that touches the kicker once outside the kicking box before touching the ground in foul territory (see Rule 1.04);
7. a kicked ball by a male player that touches a defender prior to reaching the 1st-3rd diagonal line.

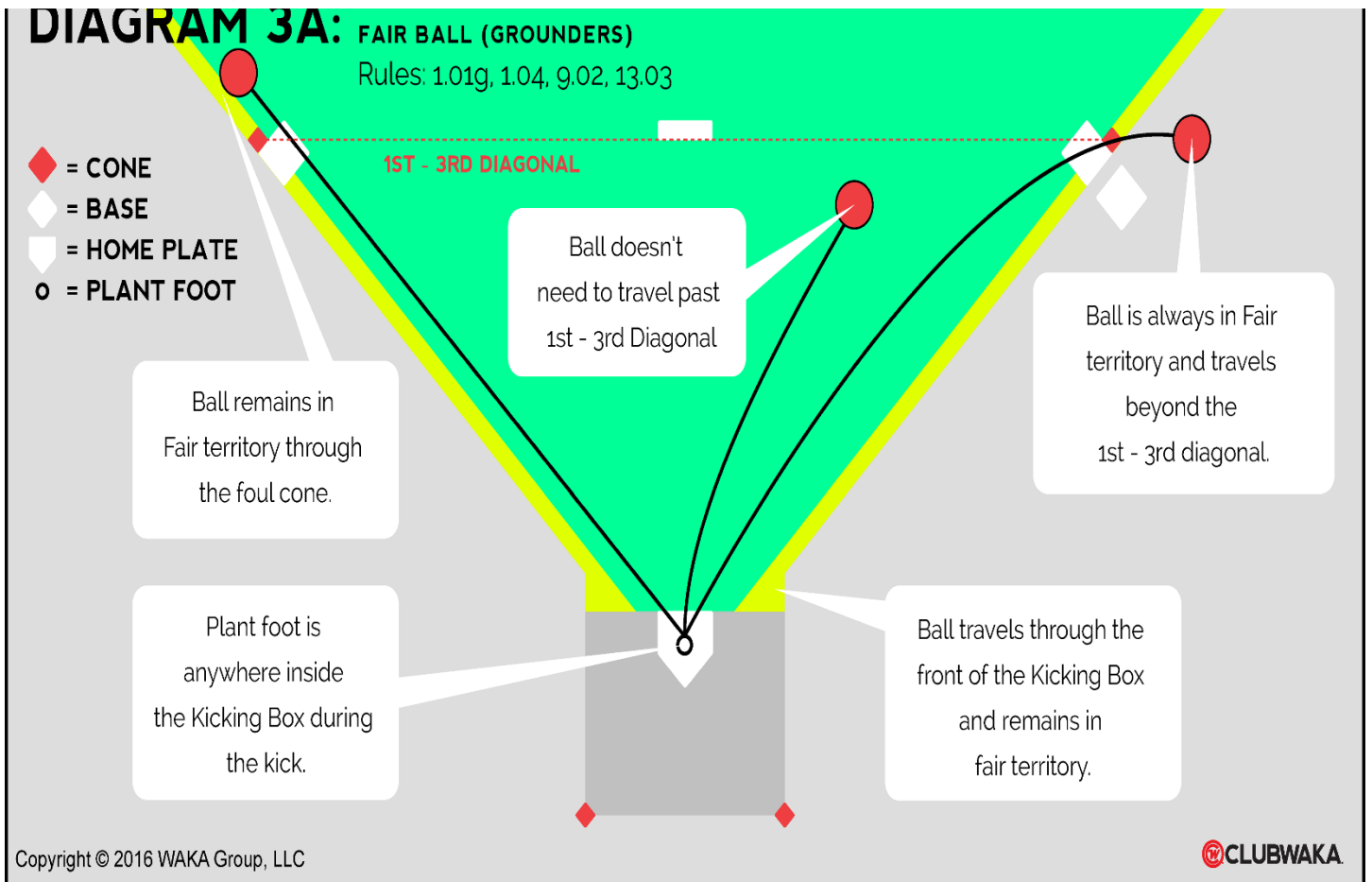

LVAF/WAKA Kickball Rules

DIAGRAM 3B: FAIR BALL (IN THE AIR/BOUNCING)

Rules: 1.01g, 1.04, 9.02, 13.03

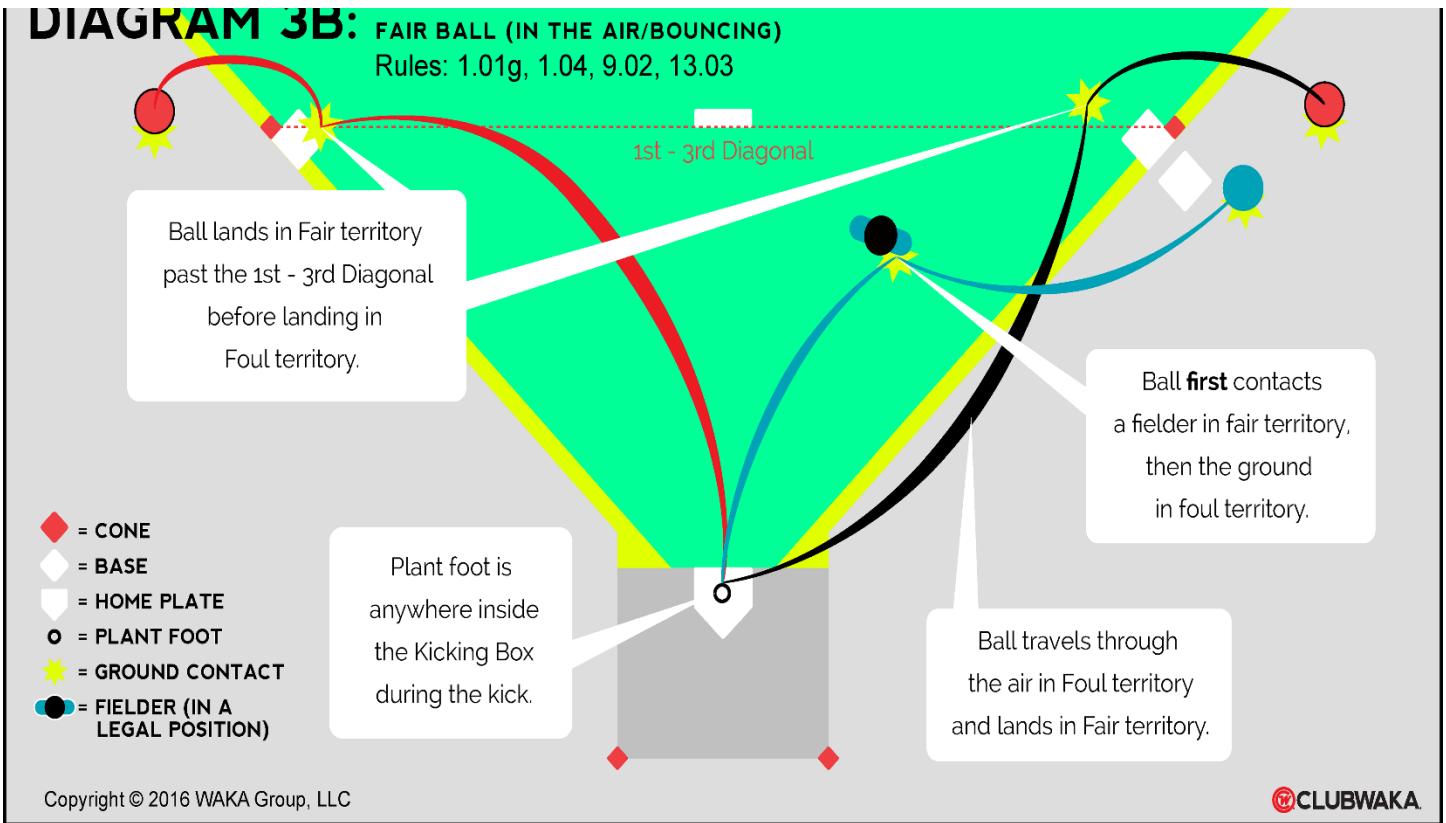
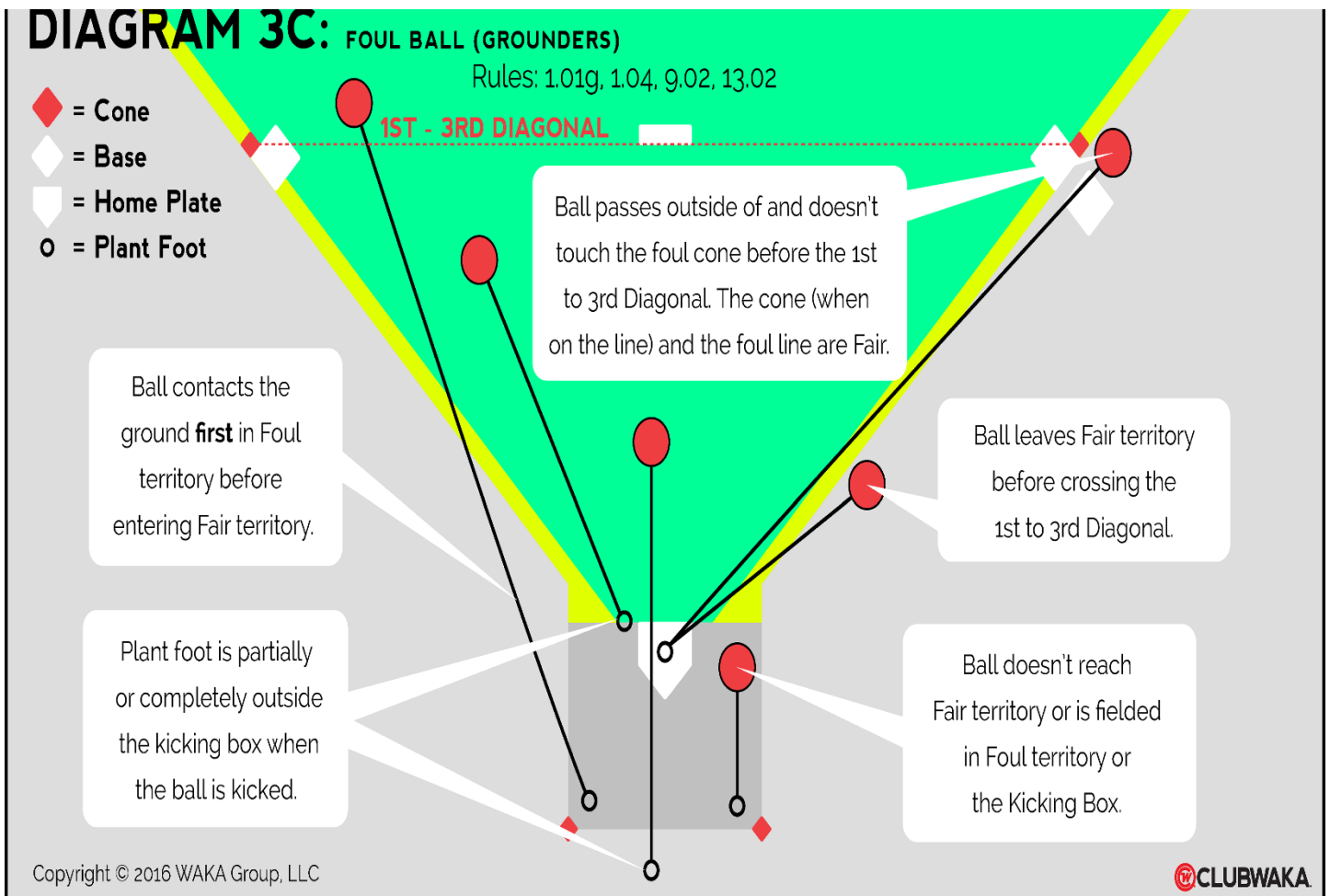
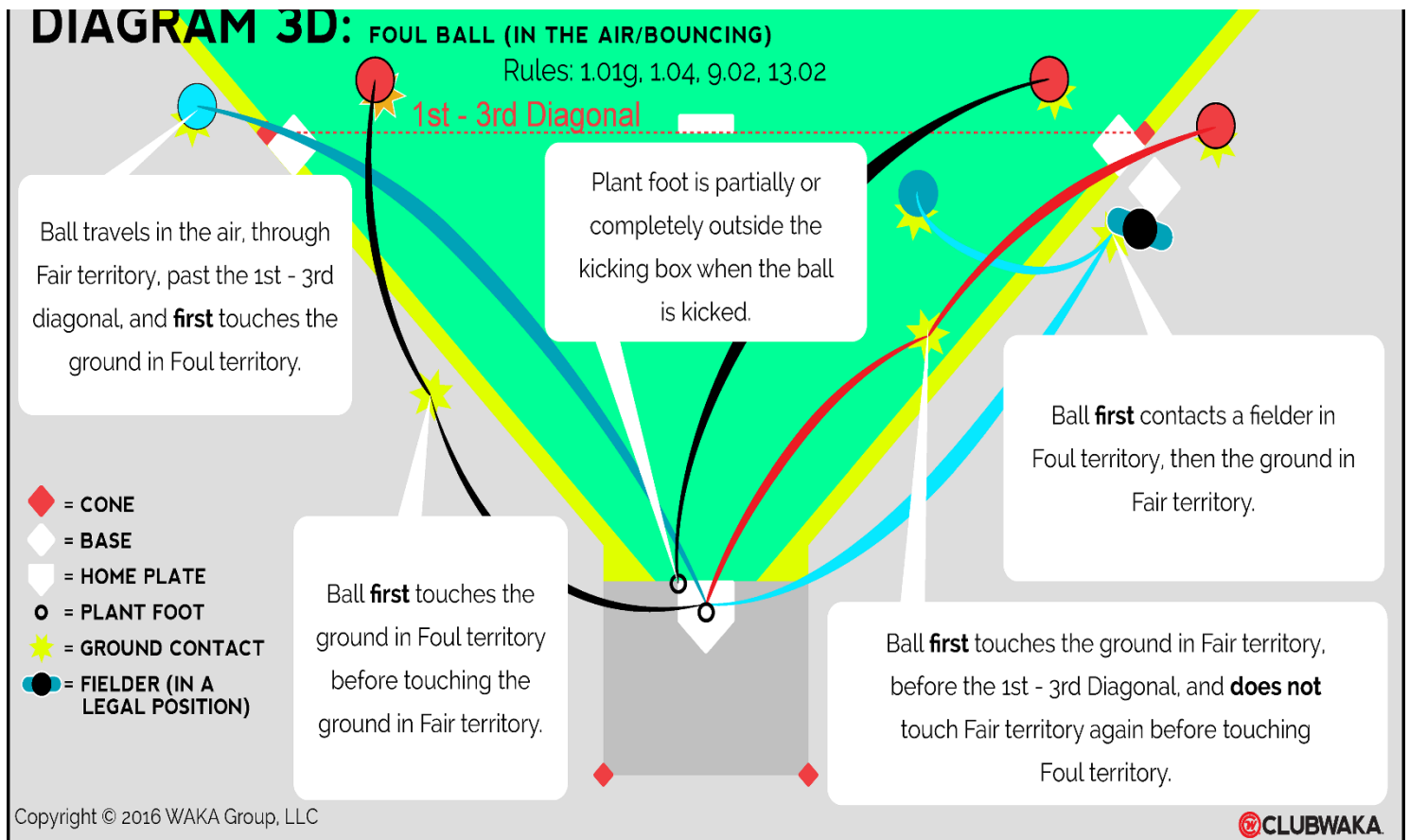

DIAGRAM 3C: FOUL BALL (GROUNDERS)

Rules: 1.01g, 1.04, 9.02, 13.02



LVAF/WAKA Kickball Rules



14. Outs

14.01 A count of three (3) outs by a team completes the team's half of the inning.

14.02 An out is:

1. a count of three (3) strikes or three (3) fouls;
2. any kicked ball (fair or foul) that is caught by a fielder. Any part of the ball may incidentally touch the ground during the act of catching and still be ruled an out if the fielder first displays full control of the ball and maintains control after touching the ground;
3. a Force Out, being the tag by any part of a fielder's body of a base to which a runner is forced to run, before the runner arrives at the base, while the fielder has control of the ball. The ball may be touching the ground if the fielder displays full control of the ball while simultaneously tagging the base;
4. a runner touched by the ball or who touches the ball at any time while not on base while the ball is in play;
5. a kicker or runner that interferes with the ball (see Rules 15.02b and c);
6. a tag of a base by any part of a fielder's body, while the fielder has control of the ball (see Rule 14.02c), before the runner originating at that base can tag-up as required due to a caught ball (see Rule 10.05);
7. a runner off base when the ball is kicked (see Rule 10.03);
8. a runner physically assisted by a team member during play (see Rule 6.02);
9. any kicker that does not kick in the proper kicking line up (see Rule 4.02);
10. a runner that passes another runner (see Rule 10.08);
11. a runner outside of the baseline (see Rule 10.01);
12. a runner who misses a base, as called by a Referee upon the conclusion of the play;

LVAF/WAKA Kickball Rules

13. a runner who fails to properly tag up on a caught ball, as called by a Referee upon the conclusion of the play;
14. a runner touched by the ball while on a base they are forced to vacate by the kicker becoming a runner;
15. a runner coming from home plate who steps on First Base when required to use the Extra Base (while an Extra Base is in use - see Rule 1.06);
16. a player improperly occupying the sideline area after their team has been issued a warning (see Rule 1.07).

15. Ball In Play

15.01 Once the pitcher has the ball in control and retains possession on the mound, the play ends. Runners who are off base at this time and in forward motion may advance only one base. Runners who are off base at this time and not in forward motion must return to the base from which they were running.

15.02 Interference is:

1. when any non-fielder or non-permanent object except a Referee or a runner, touches or is touched by a ball in play in fair territory. This interference causes the play to end, and runners shall proceed to the base to which they were headed;
2. when any runner on or off base intentionally touches a ball, or hinders a fielder. This interference causes the play to end, the runner to be out, and any other runners shall return to the base from which they came, unless forced to advance (see Rule 14.02e);
3. when any kicker intentionally touches a pitched ball by hand or arm before the pitch is called a Ball or Strike, or intentionally touches a kicked ball to render it foul. This interference causes the play to end, the kicker to be out, and any runners shall return to the base from which they came (see Rule 14.02e).

15.03 During any play where a ball is popped or deflates significantly, that play shall be replayed with a properly inflated ball.

16. Injury and Substitution

16.01 In cases of injury or illness, a time-out may be requested for participant removal and replacement with a teammate as a substitute. If the participant later returns to play, the participant must be inserted in the same written kicking order position previously held.

16.02 If a player is ejected, injured, becomes ill and cannot continue, or leaves the game for any reason, the written kicking order will continue in the same formation, less the removed player. A player removed from the kicking order for ejection, injury, illness, or any reason does not constitute an improper kicking order (per. 4.02) and there is no "automatic out" when the removed player's spot in the order is reached.

16.03 Injured players who do not kick shall not play in the game.

16.04 Any player removed from the game for injury or illness must be noted on both team written kicking orders and mentioned to the Head Referee.

16.05 The pitcher and the catcher positions may only be replaced once per inning each, unless injury forces another substitution.

16.06 Only runners who are injured while traveling to a base, and who successfully make it to a base, may be substituted. There are no other allowable runner substitutions. A runner may be substituted no more than twice during the game. Upon the second substitution, the player will be removed from the game and no longer be allowed to participate.

17. Other

LVAF/WAKA Kickball Rules

17.01 The spirit of these rules is to ensure a fun environment and participant enjoyment. All games are to be played in a sportsmanlike manner. If necessary, the World Adult Kickball Association (WAKA) / CLUBWAKA will address any inconsistencies, discrepancies, and misunderstandings in accordance with the spirit of these rules. These rules are maintained at clubwaka.com and are subject to change without notice.